

1:1 Flux Coupled Balun Transformer
5 - 120 MHz

M/A-COM Products
Part Status: Released Rev V2

Features

- Surface Mount
- 1:1 Impedance
- 75 Ohm
- RoHS Compliant

Description

M/A-COM's MABA-009109-CF1A40 is a 1:1 RF flux coupled Transformer in a low cost surface mount package. Ideally suited for high volume CATV application.

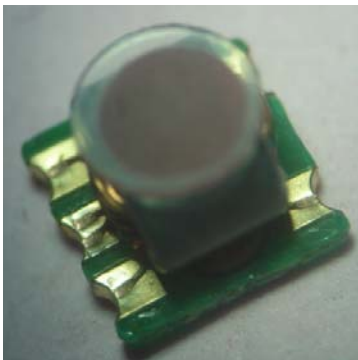

Schematic

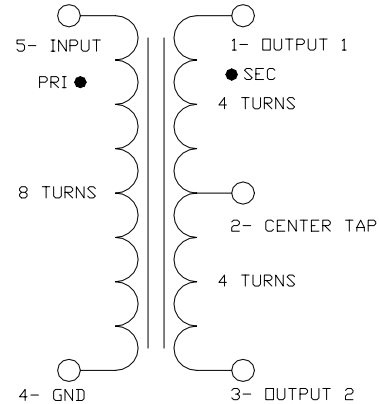

Pin Configuration

Function	Pin Number
Secondary Dot (Output 1)	1
Secondary Centre Tap	2
Secondary (Output 2)	3
Primary (Ground)	4
Primary Dot (Input)	5

Ordering Information

Part Number	Package
MABA-009109-CF1A40	2000 pieces per reel
MABA-009109-CF1ATB	Customer test board

Case Style SM-164A

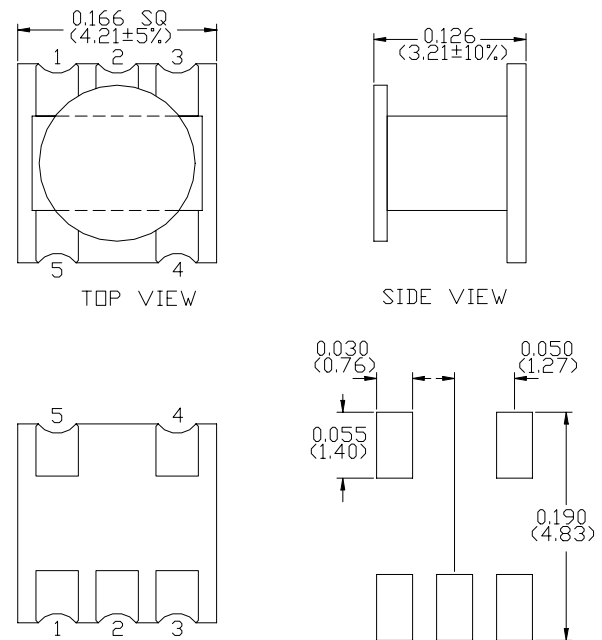

Dimensions are inches (millimeters) ± 0.015 (0.38) unless otherwise specified.

ADVANCED: Data Sheets contain information regarding a product M/A-COM is considering for development. Performance is based on target specifications, simulated results, and/or prototype measurements. Commitment to develop is not guaranteed.

PRELIMINARY: Data Sheets contain information regarding a product M/A-COM has under development. Performance is based on engineering tests. Specifications are typical. Mechanical outline has been fixed. Engineering samples and/or test data may be available. Commitment to produce in volume is not guaranteed.

- **North America** Tel: 800.366.2266 / Fax: 978.366.2266
- **Europe** Tel: 44.1908.574.200 / Fax: 44.1908.574.300
- **Asia/Pacific** Tel: 81.44.844.8296 / Fax: 81.44.844.8298

Visit www.macom.com for additional data sheets and product information.

M/A-COM Inc. and its affiliates reserve the right to make changes to the product(s) or information contained herein without notice.

1:1 Flux Coupled Balun Transformer
5 - 120 MHz

M/A-COM Products
Part Status: Released Rev V2

Electrical Specifications: $T_A = 25^\circ\text{C}$, 0dBm, $Z_0 = 75\Omega$

Parameter	Test Conditions	Units	Min.	Typ.	Max.
Frequency Range	5 – 120 MHz				
Insertion Loss 1 (Pin 5 to Pin 1)	5 – 75 MHz	dB	–	0.1	0.4
	75 – 120 MHz	dB	–	0.3	0.6
Insertion Loss 2 (Pin 5 to Pin 3)	5 – 75 MHz	dB	–	0.2	0.4
	75 – 120 MHz	dB	–	0.4	0.5
Amplitude Un-Balance	5 – 75 MHz	dB	–	± 0.03	± 0.17
	75 – 120 MHz	dB	–	± 0.12	± 0.38
Phase Un-Balance	5 – 75 MHz	$^\circ$	–	± 0.05	± 2.0
	75 – 120 MHz	$^\circ$	–	± 0.10	± 3.0
Input Return Loss (Pin 5)	5 – 75 MHz	dB	20	28	–
	75 – 120 MHz	dB	15	19	–

Absolute Maximum Ratings

Parameter	Absolute Maximum
RF Power	250mW
DC Current	30mA
Operating Temperature	-40°C to $+100^\circ\text{C}$
Storage Temperature	-40°C to $+100^\circ\text{C}$

Recommended PCB Configuration

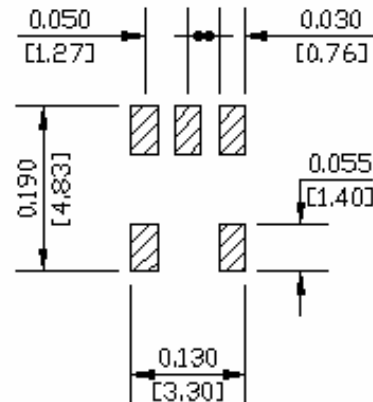

1:1 Flux Coupled Balun Transformer
5 - 120 MHz

M/A-COM Products
Part Status: Released Rev V2

Typical Performance: $T_A = 25^\circ\text{C}$, 0dBm, $Z_0 = 75\Omega$

Insertion Loss 1 (Pin 5 - Pin 1)

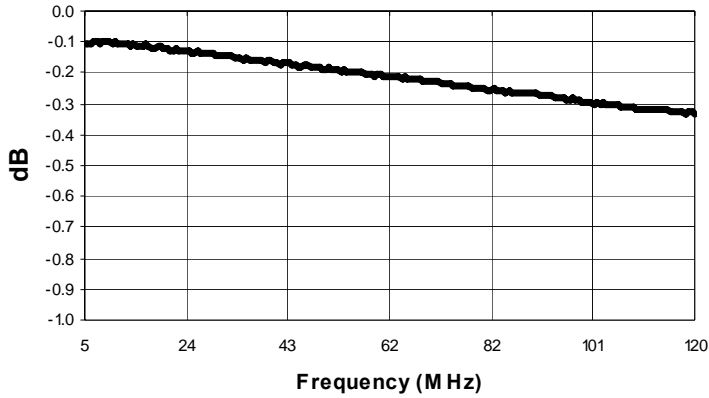

Insertion Loss 2 (Pin 5 - Pin 3)

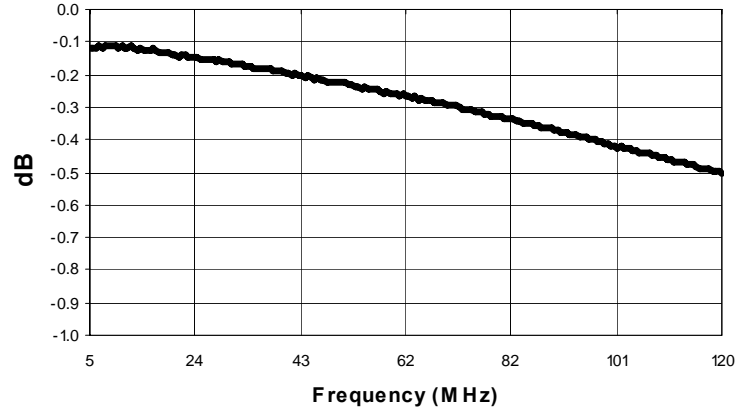

Amplitude Balance

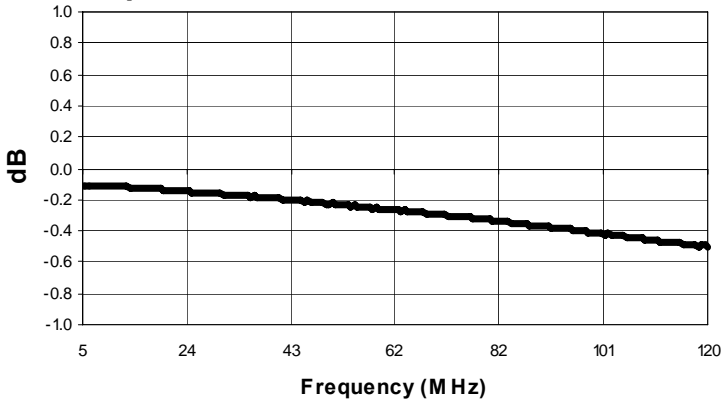

Phase Balance

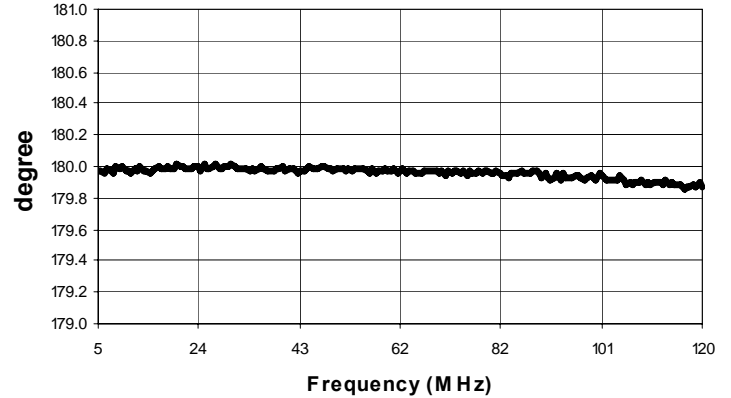

Return Loss: Input (Pin 5)

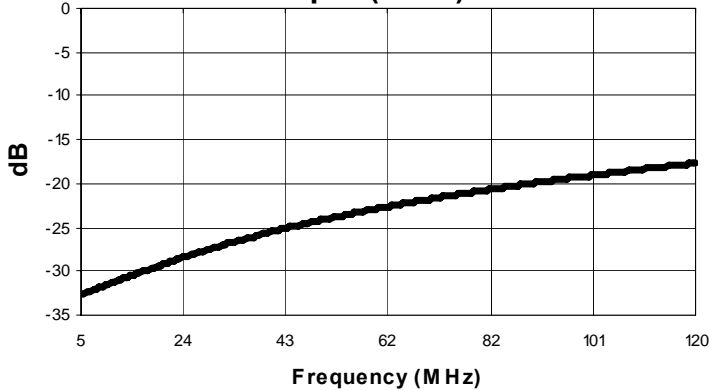

ADVANCED: Data Sheets contain information regarding a product M/A-COM is considering for development. Performance is based on target specifications, simulated results, and/or prototype measurements. Commitment to develop is not guaranteed.

PRELIMINARY: Data Sheets contain information regarding a product M/A-COM has under development. Performance is based on engineering tests. Specifications are typical. Mechanical outline has been fixed. Engineering samples and/or test data may be available. Commitment to produce in volume is not guaranteed.

- **North America** Tel: 800.366.2266 / Fax: 978.366.2266
- **Europe** Tel: 44.1908.574.200 / Fax: 44.1908.574.300
- **Asia/Pacific** Tel: 81.44.844.8296 / Fax: 81.44.844.8298

Visit www.macom.com for additional data sheets and product information.

M/A-COM Inc. and its affiliates reserve the right to make changes to the product(s) or information contained herein without notice.